

FRANKE MARATHON

Installation instructions for Franke faucet FF 1450



Please read our instruction before you install and use the tap. This instruction should be given to taps consumer.

Franke Consumer Product, Inc.
Kitchen Systems Division
Suite 500
3050 Campus Drive/Hatfield, PA 19440

Tel. 800-626-5771
Telefax 215-822-5873
www.frankeksd.com

Design. These faucets are available in Stainless steel. The elegant rising spout has a high clearance from sinktop level giving plenty of room to fill or wash pots. This clearance is particularly important with accessorized sinks where the accessories bring the bowl to countertop level when in use.

Care of finish. These faucets have been carefully manufactured. The surface will maintain its appearance for a long time, provided it is cleaned using a soft cloth, water and soap. NEVER use an abrasive cleanser (liquid or powder) or any scouring pad on this faucet.

Limited Warranty. Congratulations on the purchase of a Franke product. Franke is one of the world's largest manufacturers of kitchen systems worldwide. Our products are manufactured using the highest degree of technology, quality and design. As a result, we are proud to offer the following warranty.

Franke, Inc., Kitchen Systems Division, warrants the quality of its faucets to be free from manufacturing defects for life from the date of purchase.

This warranty applies only to the original owner, providing the product as been installed in accordance with our installation instructions, used as recommended and in a normal residential application. In the event of a warranty claim, the owner will be required to provide proof of purchase. This warranty covers all components which make the product operational. Franke, at its option, may repair or replace the product or components necessary to restore the product to good working condition. Franke reserves the right to inspect the installation prior to the actual replacement of the product or component part.

This warranty does not cover misuse or abuse, accidental damages, scuffs or scratches improper installation, abnormal usage, negligence or damage caused by improper maintenance or cleaning. Normal wear of parts is excluded from warranty. Damage caused by impurities or acts beyond our control are not covered. Any product or part which has been repaired or altered in any manner outside of Franke's factory, unless previously authorized in writing by Franke, will void warranty. Any replacement excludes transportation and any labor re-installation costs. This warranty does not allow recovery of incidental or consequential damages such as loss of use, delay, property damage or other consequential damage, and Franke accepts no liability for such damages.

The Franke warranty is limited to the above conditions and to the warranty period specified herein and is exclusive. Franke **DISCLAIMS** all other warranties, expressed or implied, including the **IMPLIED WARRANTIES OF MERCHANTABILITY AND/OR FITNESS FOR A PARTICULAR PURPOSE.** This warranty gives you specific legal rights which may vary from state to state.

Complete warranty available through Franke INC.

TECHNICAL DATA

Maximum water pressure:	75 PSI
Maximum hot water temperature:	175° F
Recommended hot water temperature:	150° F
Flexible hoses connections	9/16-24 UNEF

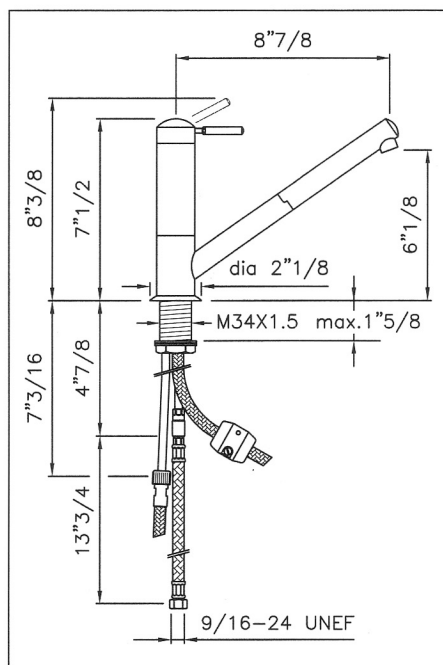

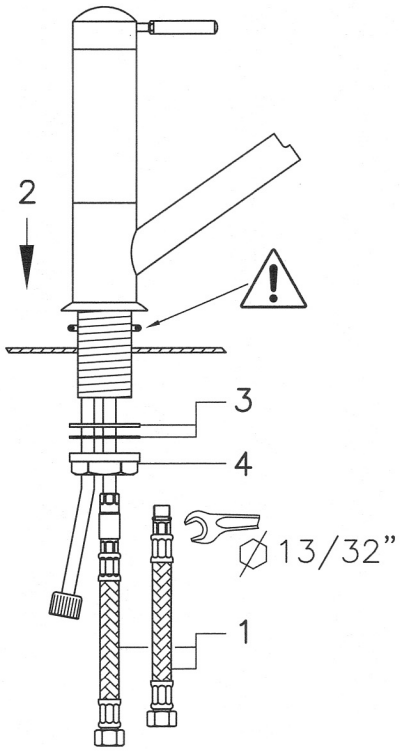
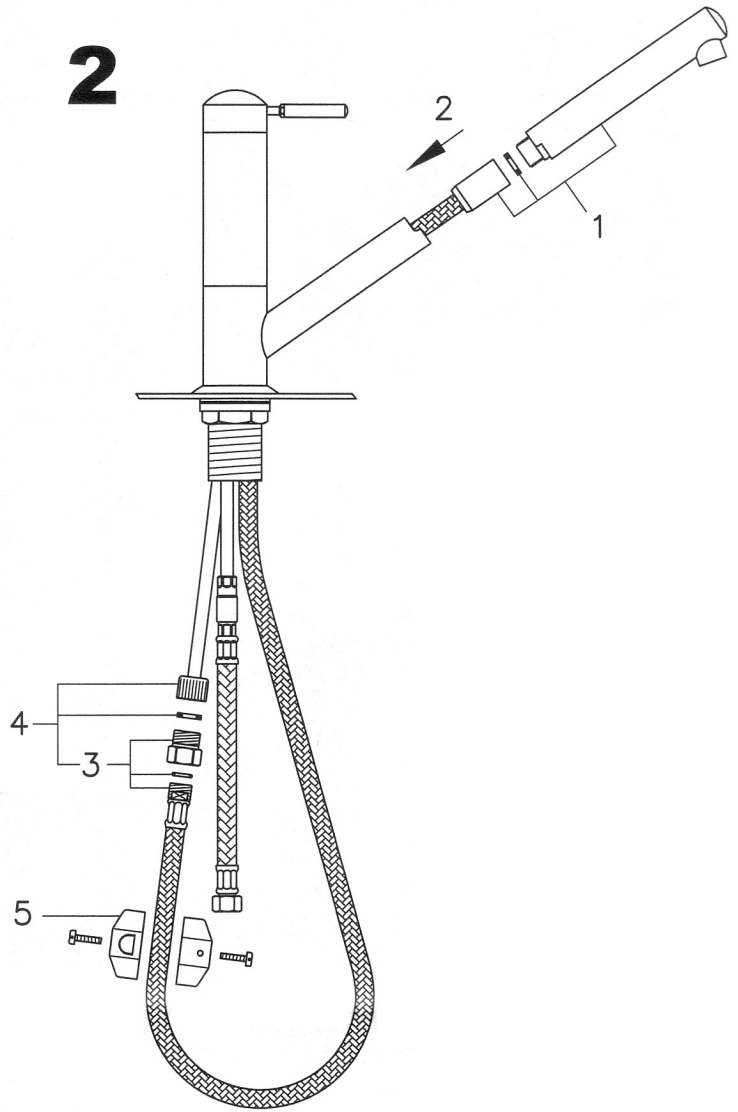
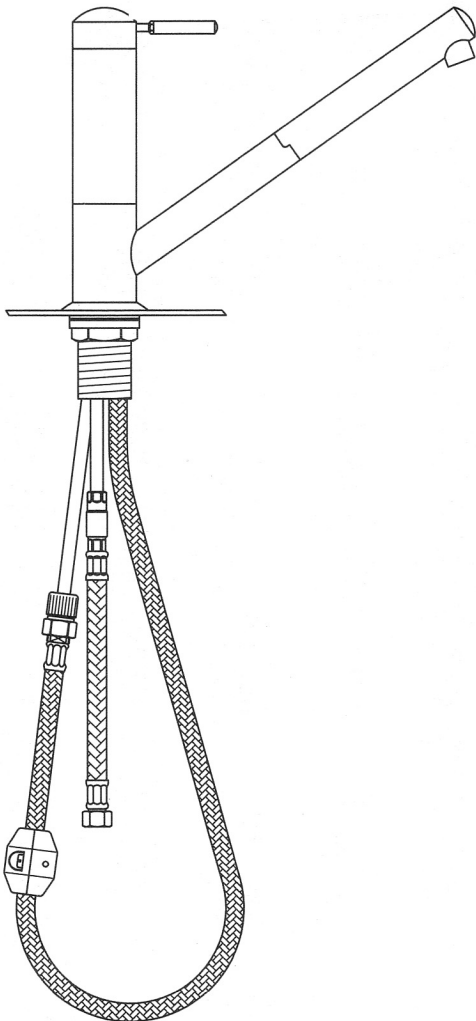
1**2****3**

Exchange of mechanism 88014

