



## **FFP 1000 SERIES**

Swivelling spout faucet with spray head

**Installation guide**

**TECHNICAL DATA**

- Minimum working pressure 0,5 bar
- Maximum working pressure 5 bar
- Recommended working pressure 3 bar (in case of water pressure higher than 5 bar it is recommended to install pressure reducers)
- Maximum working temperature 70°C

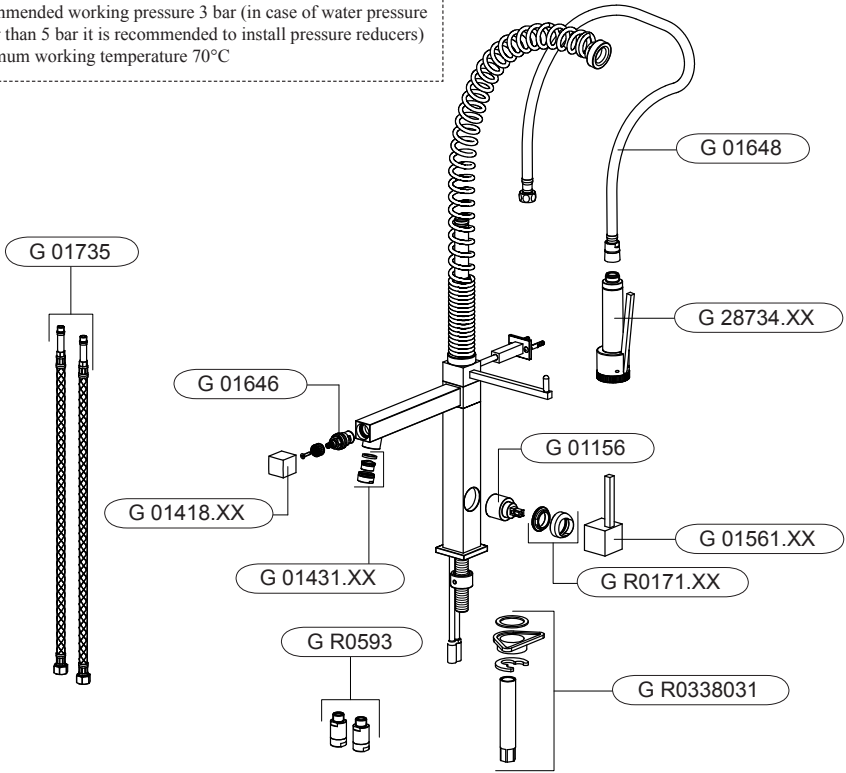

**PARTS LIST**

G 1561.XX	Handle
G R0171.XX	Ring cap
G 01156	Cartridge
G R0338031	Fastening set (rubber washer, triangular flange, metal washer, nut)
G R0593	Valve-holder
G 01735	Supply flexible hose
G 01648	Flexible hose
G 28734.XX	Spray head
G 01431.XX	Aerator
G 01646	Headvalve
G 01418.XX	Knob

**TECHNICAL FEATURES**

- Maximum water flow 2.2 gpm - 60 psi
- Recommended pressure range 15-75 psi - Over 75 psi PRV required
- Complies with Proposition 65, NSF61, UPC and C-UPC requirements

## Faucet installation

Please remove all components from package and inspect prior to installation (see itemized table and picture).

### NOTE:

**Call us immediately if you see inconsistencies. (1-800-626-5771)**  
or visit  
**[www.frankeksd.com](http://www.frankeksd.com)**

TABLE OF CONTENTS

1	Faucet
2	Wall fastening set
3	Wall flange (over the sink)
4	Wall flange (under the sink)
5	Fastening set (rubber washer, triangular flange, metal washer, nut)
6	Non-return valves

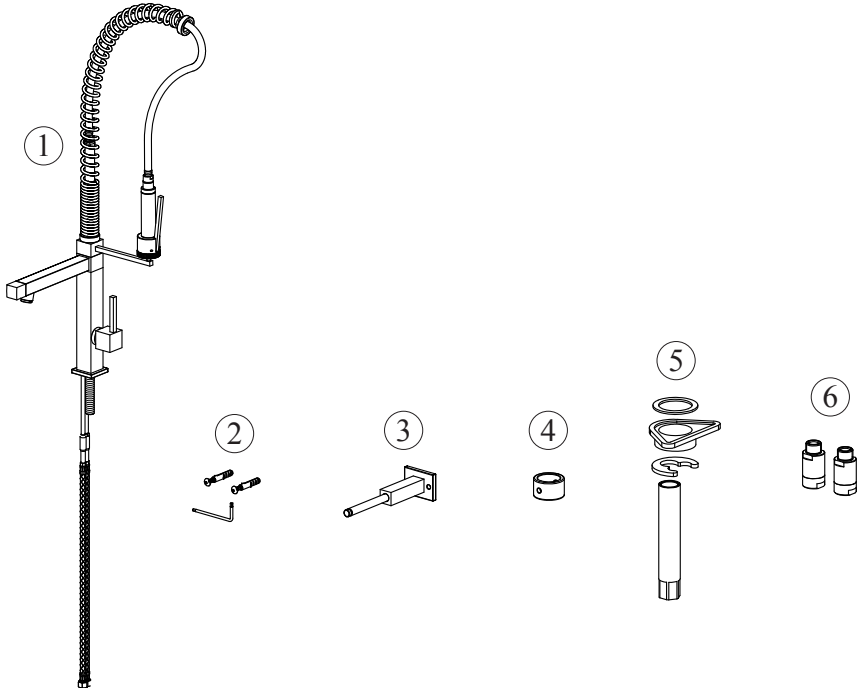

- Remove all mounting hardware from protecting plastic bag.
- Place the large O-ring over the faucet shank and place the faucet into the desired location.

**NOTE:**

**the rubber O-ring should be sitting on top of the countertop and between the faucet body. DO NOT use putty or other sealant at this location**

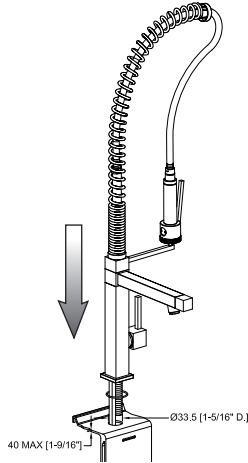

- Install the mounting hardware (G R0338031) to the threaded shank in the following sequence:

- 1 - round flat fiber washer
- 2 - triangular shaped plastic support
- 3 - flat metal washer
- 4 - thread brass nut

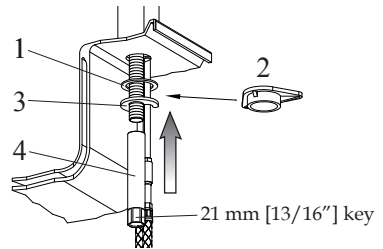

- Assure that the handle and spout are properly aligned in forward position
- Tighten the brass nut (4) with the provided wrench or use other professional tools.
- Connect the supply flexible hoses to the supply net, interposing between-them the non-return valve with the gaskets as indicated in the figure.

**NOTE:**

**solid surface installation:** The sub-countertop mounting surface needs to be flat and free of debris; otherwise the faucet will not sit properly.

**Tile installation:** Avoid installations near or on top of grout lines. The faucet will not sit secure when sitting on such.

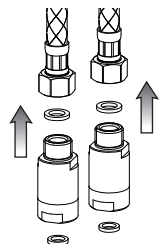

7. The body can be fixed both onto the wall and on surface: .
1. Screw the fixing rail onto the single lever body.
  2. Insert it completely in the given plate.
  3. Place the single lever body into the sink hole made at a certain distance from the wall.
  4. Place the plate properly where it has to be fixed, making sure the drilling points on the wall are well marked corresponding to the two holes with a 28 mm [1-1/8"] interaxe.
  5. Place the dowels in the holes.
  6. Fix the plate onto the wall with the given screws.
  7. give stability to the position of the single lever by acting on the fixing rail and block the movement with the given nut.

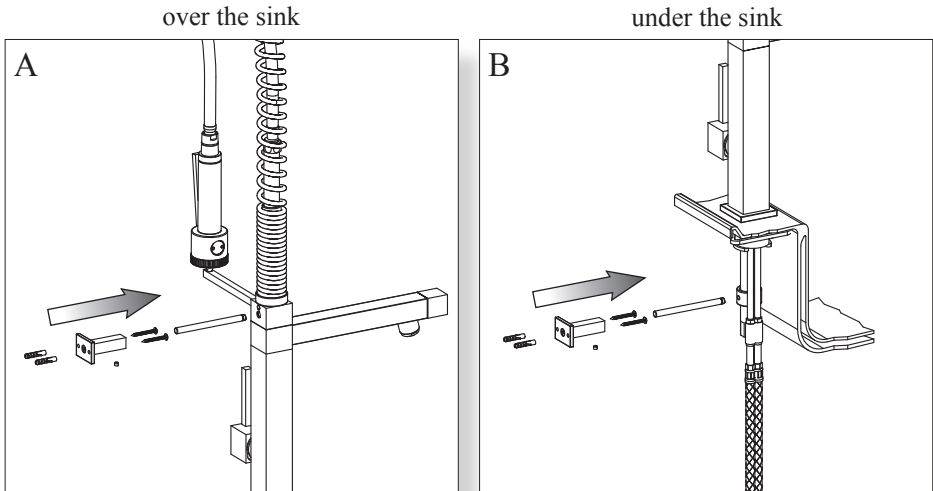

8. Flush out debris from water lines and faucet.
1. Pull spray hose out of the faucet spout and point the open end towards the sink drain.
  2. Open faucet handle - cold side first - by turning handle to the right and moving it upward.
  3. Let the faucet run on cold for 15 to 30 seconds.
  4. Open faucet handle - hot side second - by turning handle to the left and moving it upward.
  5. Let the faucet run on cold for 15 to 30 seconds.
  6. Turn faucet off.
  7. Test for leaks under the cabinet.

# Standard maintenance and trouble shooting

## Cleaning of the spray head

Any deposits which may accumulate on the nozzle can be removed by simply running a finger over the rubber extrusions and then running the water for a few seconds. In extreme cases this step may have to be repeated.

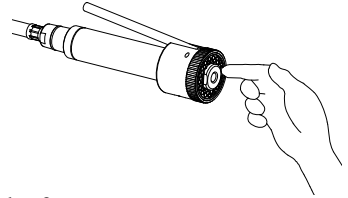

## Replacing the Cartridge

1. Shut off the water supply to the faucet.
2. Open the faucet briefly to relief any pressure inside the faucet.
3. Move the faucet handle to the "OFF" position.
4. Use a the provided allen key to loosen the set screw which is accessible from the back of the handle.
5. Lift the handle from the cartridge.

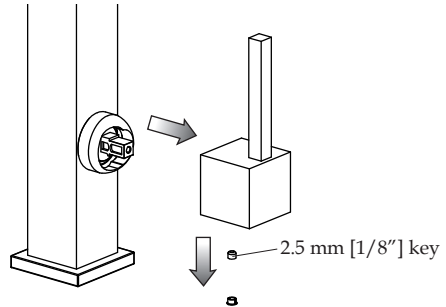

6. Find the small notch at the base of the chrome ring cap and carefully pry up against this to remove the cap.

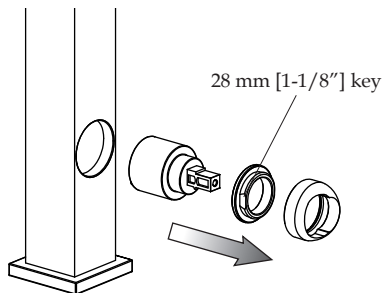

7. Remove the brass retaining ring.
8. Lift out the cartridge.
9. Ensure that the seats and O-rings are in good condition.
10. Remove potential mineral deposits from inside the faucet body.
11. Install the new cartridge so that the central pivots fit into the corresponding seats.
12. Re-assemble faucet in reverse order.
13. Test for leakage.

### **Replacing the Headvalve**

1. Shut off the water supply to the faucet.
2. Open the faucet briefly to relief any pressure inside the faucet.
3. Move the faucet knob to the “OFF” position.
4. Use a the provided allen key to loosen the set screw which is accessible from the back of the handle.
5. Lift the handle from the headvalve.
6. Unscrew then the headvalve using a 17 mm wrench and replace it.
7. Reinstall all the details, proceeding in opposite order.

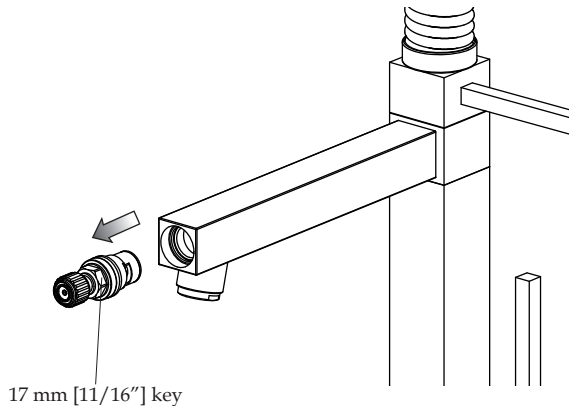
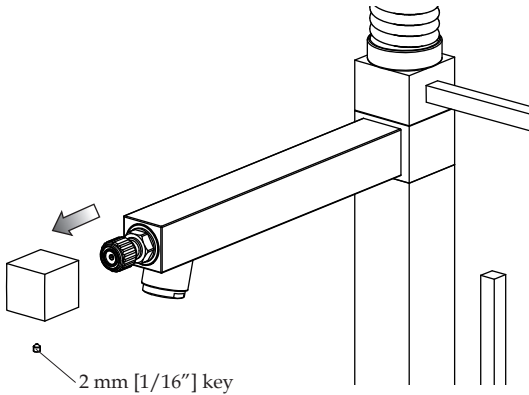

### **General maintenance**

Clean aerator periodically.

Do not use harsh detergents, solvents, chemical agents, metallic sponges, etc. that could harm the surface.

Clean only with a soft sponge and soapy water,

Clean and then dry properly the faucet in case of very hard or calcareous water, whose deposits could damage the surface.

## Limited lifetime warranty

Franke Consumer Products, Inc., Kitchen Systems Division extends the following warranty to the original purchaser of its faucets effective January 1, 2003.

All faucets installed in a private residence will carry a *limited lifetime warranty* on all mechanical parts to be free of manufacturing defects in material and workmanship under normal usage. *All chrome finishes carry a limited lifetime warranty; all other finishes are warranted for five (5) years from the original date of purchase.*

**Marine and Outdoor Installation:** Franke Consumer Products, Inc. faucets are NOT warranted for Marine and Outdoor installations.

This warranty applies only to the original owner, providing the product has been installed in accordance with our installation instructions, used as recommended and in a normal residential application. **In the event of a warranty claim, the owner will be required to provide proof of purchase - save sales receipt.** This warranty covers all components which make the product operational. Franke, at its option, may repair or replace the product or components necessary to restore the product to good working condition. Franke reserves the right to inspect the installation *prior* to the actual replacement of the product or component part.

This warranty does not cover misuse or abuse, accidental damages, scuffs or scratches, improper installation, abnormal usage, negligence or damage caused by improper maintenance or cleaning. Normal wear of parts is excluded from the warranty. Damage caused by impurities or acts beyond our control are not covered. Any product or part which has been repaired or altered in any manner outside of Franke's factory, unless previously authorized in writing by Franke, will void warranty. ***Any replacement excludes transportation and any labor re-installation costs.*** This warranty does not allow recovery of incidental or consequential damages such as loss of use, delay, property damage or other consequential damage, and Franke accepts no liability for such damages.

The Franke warranty is limited to the above conditions and to the warranty period specified herein and is exclusive. Franke **DISCLAIMS** all other warranties, expressed or implied, including **IMPLIED WARRANTIES OF MERCHANTABILITY AND/OR FITNESS FOR AS PARTICULAR PURPOSE**. This warranty gives you specific legal rights that may vary from state to state.

### **Further information**

For any further information about our products, about the installation of them or about the guarantee, please dial the number of the customer service:

**Phone number +1-215-822-6590**

**Or: 1-800-626-5771**

**Fax number + 1-215-822-5873**

**Franke Consumer Products Inc. - Kitchen Systems Division  
3050 Campus Drive, Suite 500 Hatfield, PA 19440**