

FRANKE Orient-Express

Installation instructions for Franke faucet OE-300 Series

Franke Consumer Product, Inc.
Kitchen Systems Division
Suite 500
3050 Campus Drive/Hatfield, PA 19440

Tel. (800) 626-5771
Telefax (215) 822-5873
www.frankeksd.com

Please read our instruction before you install and use the tap. This instruction should be given to taps consumer.

Care of finish. Your new pot filler has been carefully manufactured. The chrome or satin nickel surface will maintain its appearance for a long time, provided it is cleaned using a soft cloth, water and soap. NEVER use an abrasive cleanser (liquid or powder) or any scouring pad on this faucet.

Main shut-off valve. For security reasons always close the main shut-off valve located at the connection of the pot filler to the wall when you are not using the pot filler for extended periods of time

Limited Warranty. Congratulations on the purchase of a Franke product. Franke is one of the world's largest manufacturers of kitchen systems worldwide. Our products are manufactured using the highest degree of technology, quality and design. As a result, we are proud to offer the following warranty.

Franke, Inc., Kitchen Systems Division, warrants the quality of its faucets to be free from manufacturing defects for life from the date of purchase.

This warranty applies only to the original owner, provided the product has been installed in accordance with our installation instructions, used as recommended and in a normal residential application. In the event of a warranty claim, the owner will be required to provide proof of purchase. This warranty covers all components which make the product operational. Franke, at its option, may repair or replace the product or components necessary to restore the product to good working condition. Franke reserves the right to inspect the installation prior to the actual replacement of the product or component part.

This warranty does not cover misuse or abuse, accidental damages, scuffs or scratches, improper installation, abnormal usage, negligence or damage caused by improper maintenance or cleaning. Normal wear of parts is excluded from warranty. Damages caused by impurities or acts beyond our control are not covered. Any product or part which has been repaired or altered in any manner outside of Franke's factory, unless previously authorised in writing by Franke, will void warranty. Any replacement excludes transportation and any labor re-installation costs. This warranty does not allow recovery of incidental or consequential damages such as loss of use, delay, property damage or other consequential damage, and Franke accepts no liability for such damages.

The Franke warranty is limited to the above conditions and to the warranty period specified herein and is exclusive. Franke **DISCLAIMS** all other warranties, expressed or implied, including the **IMPLIED WARRANTIES OF MERCHANTABILITY AND/OR FITNESS FOR A PARTICULAR PURPOSE**. This warranty gives you specific legal rights which may vary from state to state. Complete warranty available through Franke INC.

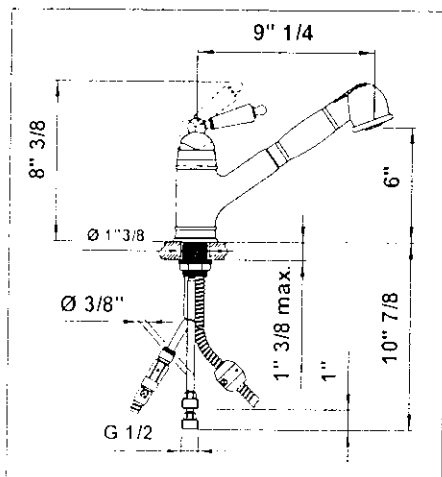

Technical data

Maximum water pressure:	75 PSI (5 bar)
Maximum hot water temperature:	175° F (80° C)
Connection:	1/2"

* where indicated specify color

1

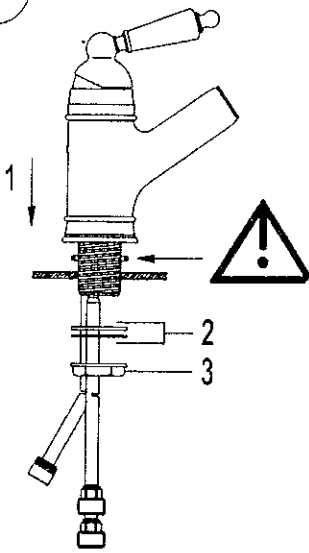

2

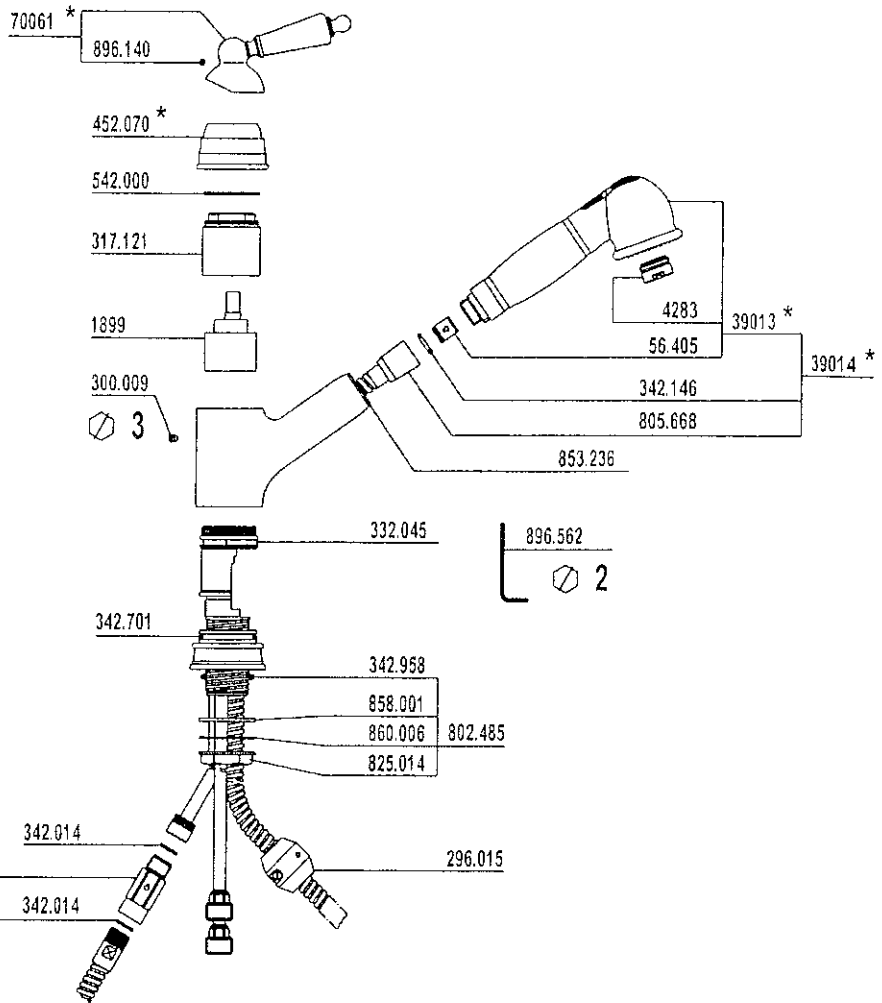
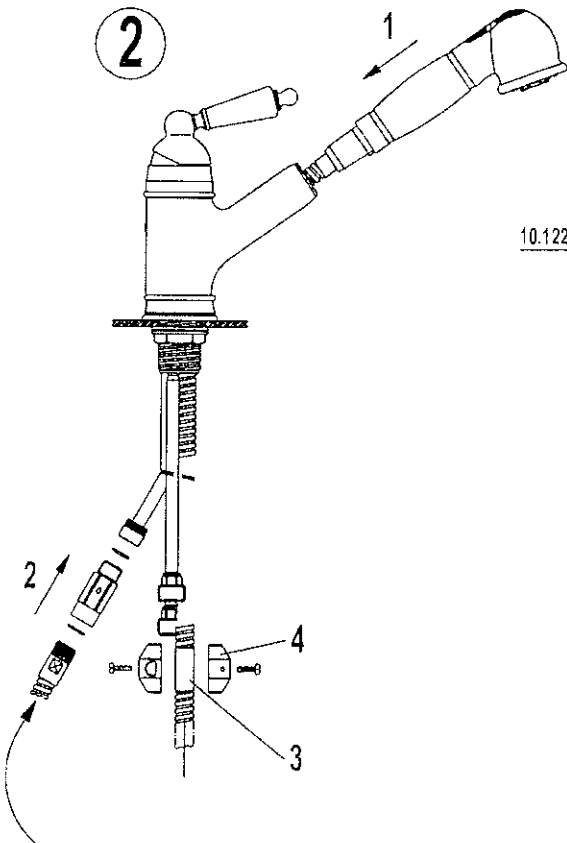

Exchange of cartridge

