



MUSTEE
Preferred by the "Pros"

TOPAZ™ Bathtub & Walls Ensemble

Fits a 60" wide x 30" deep bathtub alcove with a minimum ceiling height of 64"



Code Accepted—Bathtub and Wall Ensembles:

TOPAZ™ Fiberglass Bathtub and Wall Ensembles meet or exceed performance requirements as listed:

- International Association of Plumbing and Mechanical Officials (IAPMO)® Listed
- American National Standards Institute (ANSI) - Specification ANSI Z 124.1.2
- American Society of Testing and Materials (ASTM) – D.635, E-84 and E-162
- Inhalation Toxicity Test – to evaluate inhalation health hazards with combustible products
- CAN/LC S102-07 Burn and Smoke Test



Bathtub Features:

- Premium molded from Mustee's proprietary VARISTONE® fiberglass
- One piece molded with matched metal molds
- Apron supported by two molded fiberglass brackets
- A network of bottom and side structural support
- Ergonomically contoured back with a 40° lumbar slope
- Fits standard 30" x 60" alcove.
- Slip-resistant bottom surface
- Available in RH and LH models with an 8-1/2" x 14-1/4" drain offset.

Bathtub Wall Features:

- Direct-to-stud mounted
- Premium molded from Mustee's proprietary VARISTONE® fiberglass
- Sides interlock with center panel to form a blade & groove seal
- Available in colorfast white, bone and biscuit
- Semi-gloss, mold/mildew-resistant finish
- Fits standard 30" x 60" alcove

Specifications

Bathtub and Wall Package Models

Bathtub Model	Wall Model	Color	Overall H x W x D	Drain	UPC
T6030R	660WHT	White	76-3/4" x 60" x 31-1/4"	RH	6 71031 00000 0
T6030L	660WHT	White	76-3/4" x 60" x 31-1/4"	LH	6 71031 00000 0
T6030RBN	660BN	Bone	76-3/4" x 60" x 31-1/4"	RH	6 71031 00000 0
T6030LBN	660BN	Bone	76-3/4" x 60" x 31-1/4"	LH	6 71031 00000 0
T6030RBT	660BT	Biscuit	76-3/4" x 60" x 31-1/4"	RH	6 71031 00000 0
T6030LBT	660BT	Biscuit	76-3/4" x 60" x 31-1/4"	LH	6 71031 00000 0

Inside bathtub depth: 14-1/4"

RH=Right Hand LH=Left Hand

Top and sides have a 1-1/4" mounting flange.

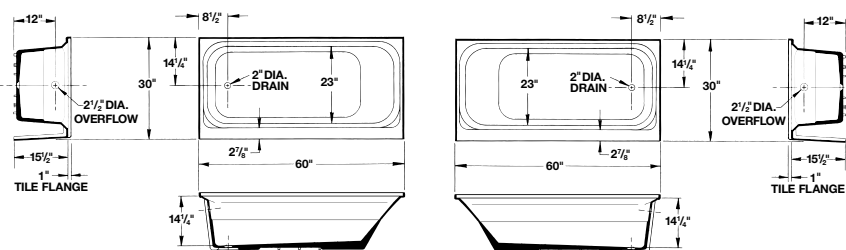
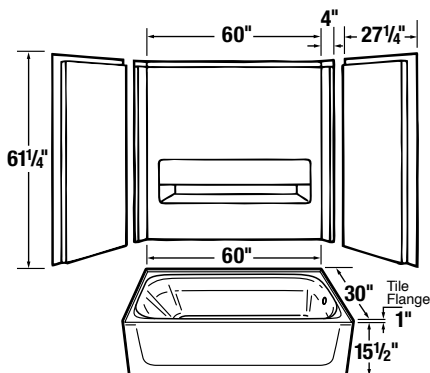

General: Furnish and install as shown on plans, TOPAZ® bathtub ensemble as manufactured by E.L. Mustee & Sons, Inc. Shall be a fiberglass 60" x 30": right hand or left hand Model _____ (T6030R or T6030L TOPAZ bathtub) with model 660 TOPAZ bathtub walls. Bathtub construction shall be molded, reinforced fiberglass using matched metal molds under extreme heat and pressure. 660 TOPAZ® Bathtub Walls shall be semi-gloss, three piece wall. Panels are molded fiberglass, using matched metal molds under extreme heat and pressure with uniform thickness of 125 mils and mount direct-to-studwalls. Include center panel with molded-in shelf and two side panels. Self-aligning panels interlock with center panel to form a blade & groove seal. Shall meet ANSI Specification Z.124.1.2. Color _____ (White, Bone, Biscuit). Total weight: 74 lbs. Install in compliance with local codes.



MUSTEE

E.L. Mustee & Sons, Inc. • 5431 West 164th Street • Brook Park, OH 44142 • Phone: 216.267.3100 • Fax: 216.267.9997
E-mail: info@mustee.com. • Web: www.mustee.com • Proudly made in the USA

Notice: Our continuous commitment to product improvement may result in changes to product specifications without notice. Patents pending. Made and Printed in U.S.A.