

Coastal Industries Inc.

FAX NO.
(904) 641-1697

P.O BOX 16091
JACKSONVILLE, FLORIDA 32245

TELEPHONE NO.
(904) 642-3970

CHALLENGER **MODULAR CORNER UNIT** **INSTALLATION INSTRUCTIONS**

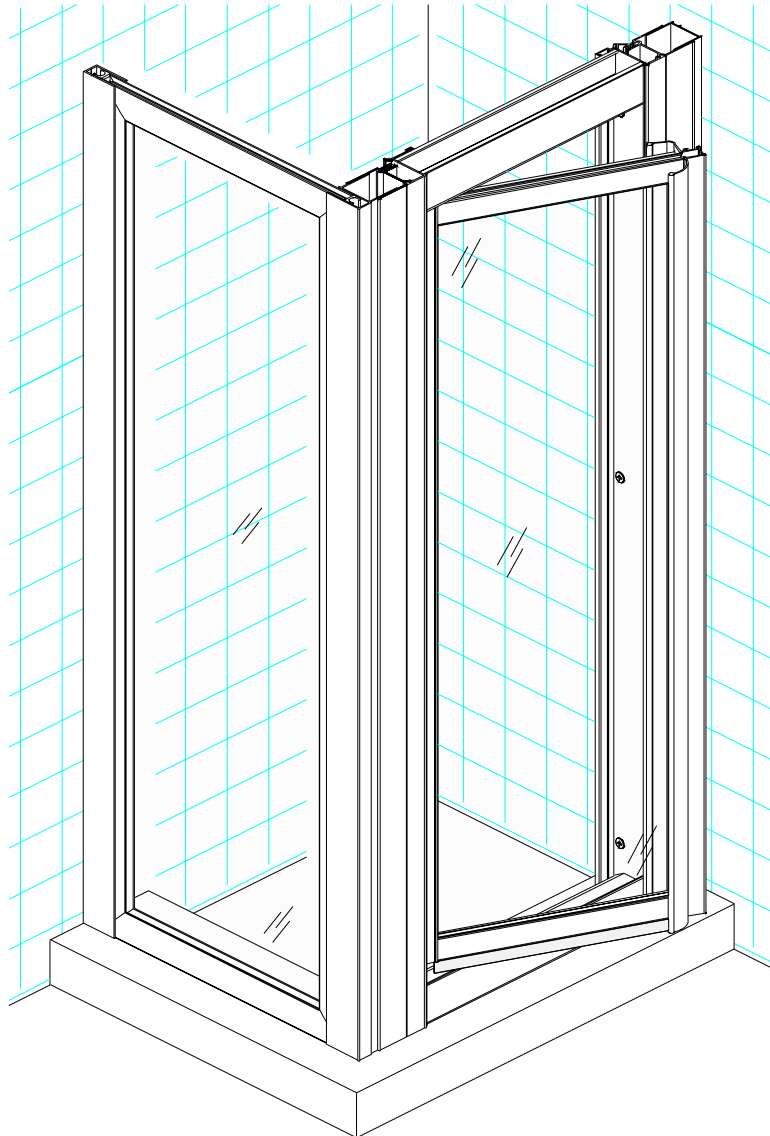

TOOLS / MATERIALS NEEDED

3/16" DRILL BIT	LEVEL	MEASURING TAPE	CENTER PUNCH	SAFETY GLASSES
ELECTRIC DRILL	HAMMER	PENCIL / FELT TIP PEN	PHILLIPS SCREW DRIVER	CLEAR CAULKING OR SEALANT (MILDEW RESISTANT)

EXPLODED VIEW OF MODULAR CORNER UNIT

(LEFT HAND PIVOT SHOWN)

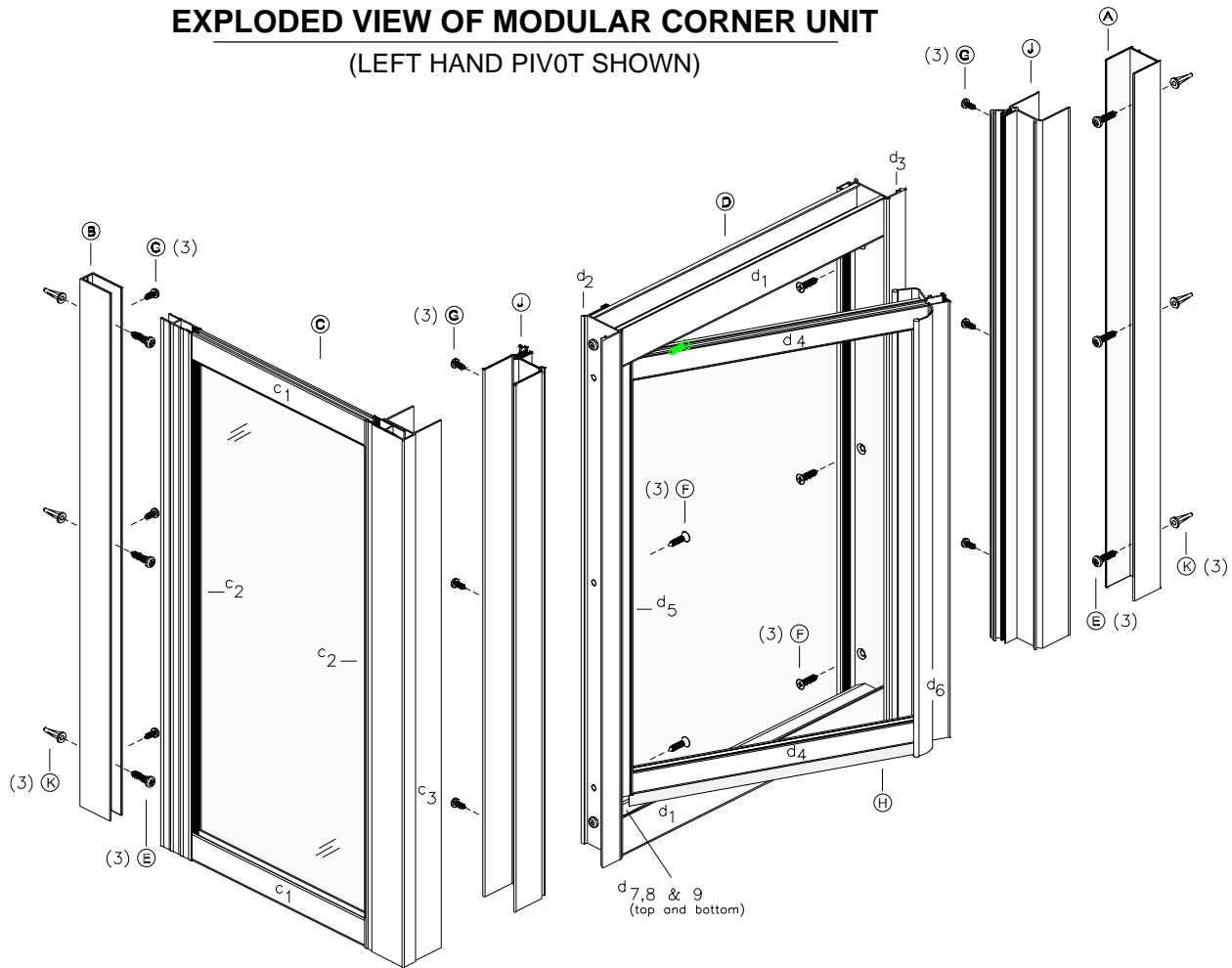

PARTS LIST

<u>KEY LETTER</u>	<u>PART NUMBER</u>	<u>DESCRIPTION</u>	<u>QUANTITY</u>
<u>A</u>	201	WALL JAMB (door)	1
<u>B</u>	271	WALL JAMB (panel)	1
<u>C</u>	---	<u>PANEL ASSEMBLY</u>	
c1	249	Panel Rails	2
c2	250	Panel Stiles	2
c3	225	90 Degree Corner Post Adapter (attached)	1
c4	834	Panel Assembly Screws (not shown)	4
c5	C154B	Panel Glazing Vinyl (not shown)	
c6	638PHPT	#6 x 3/8" Screw (90 degree to Panel)(not shown)	3
<u>D</u>	---	<u>DOOR FRAME ASSEMBLY</u>	1
d1	240	Door Frame Header / Sill	2
d2	245	Door Frame Pivot Post	1
d3	241	Door Frame Strike Post	1
d4	227	Door Panel Rails	2
d5	229	Door Panel Pivot Stile	1
d6	226	Door Panel Strike Stile	1
d7	CP201	Pivot Pin (not shown)	2
d8	CP209	Pivot Bushing (not shown)	2
d9	FW 10-093	Plastic Pivot Washer (not shown)	2
d10	98-42	Magnetic Strips (not shown)	2
d11	---	(designation not used)	--
d12	6112FHSL	Door Panel Assembly Screw (not shown)	4
d13	834	Door Frame Assembly Screw (not shown)	8
d14	C173B	Door Glazing Vinyl (not shown)	
<u>E</u>	8112	#8 x 1-1/2" PAN HEAD PHILLIPS SCREW	6
<u>F</u>	834PFH	#8 x 3/4" FLAT HEAD PHILLIPS SCREW	6
<u>G</u>	638PHPT	#6 x 3/8" SELF DRILLING PHILLIPS SCREW	9
<u>H</u>	C176B	VINYL SWEEP	1
<u>J</u>	244	EXPANDER JAMB	2
<u>K</u>	1329	PLASTIC SCREW ANCHOR	6

STEP 1

Position and Install Wall Jambs

Determine and mark the curb centerline, as shown in figure 1.

Before installing Wall Jambs . . . decide on the door location (left or right side . . . your choice). Note that there are two(2) Wall Jambs . . . one panel side (B) and one door side(A).

Position the Wall Jambs up against their respective wall and center them on the curb centerline marks, as shown in figure 1. Plumb the Wall Jambs and pencil mark their installation hole locations on the shower walls.

Remove the Jambs and drill 1-1/2" deep installation holes in the locations previously marked. Use a 3/16" masonry or ceramic bit when drilling thru ceramic tile, marble or any masonry type surface. Insert Plastic Screw Anchors (K).

Reposition Wall Jambs as before and secure to shower walls using 8112P Installation Screws (E).

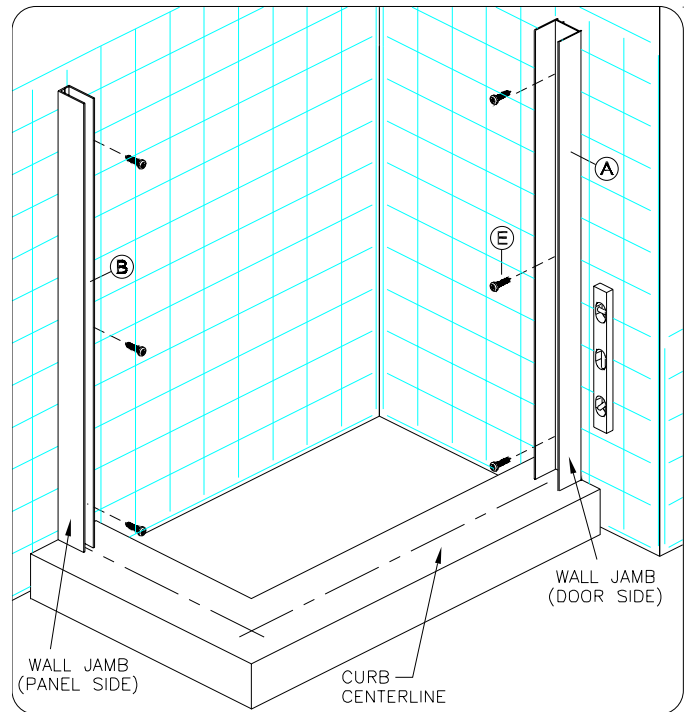

figure 1

STEP 2

Engage Expander Jambs with Door Frame

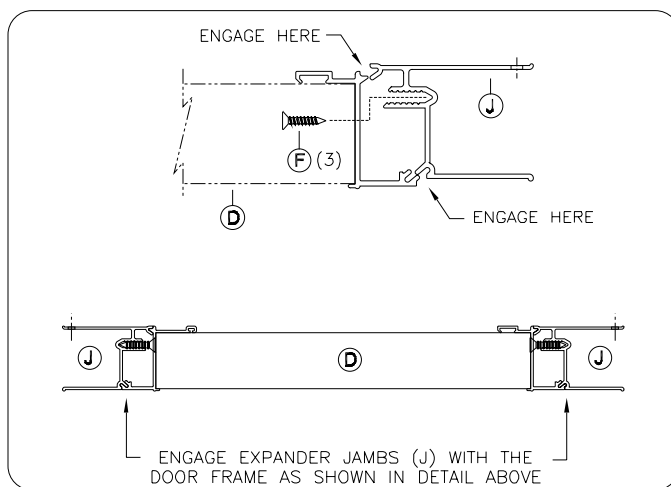

figure 2

At strike side, engage the full length of Expander Jamb with the Door Frame Assembly as shown in figure 2. Secure with three (3) #8 x 3/4" flat head screws (F). Repeat step for the hinge side.

STEP 3

Determine Door Swing and Insert Vinyl Sweep

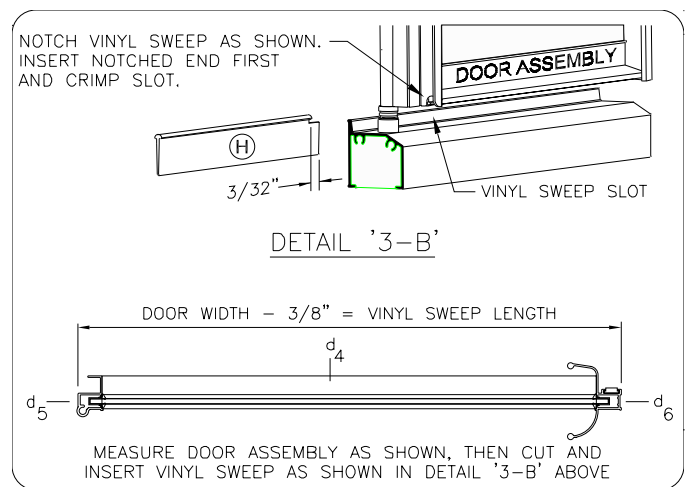

figure 3

Right or left hand pivot doors, whichever desired, can be achieved by cartwheeling door frame 180 degrees.

Determine direction of door swing at this time. Measure the Door Assembly (see figure 3c), then trim the Vinyl Sweep (H) to 3/8" less than measurement obtained. Notch one end of Vinyl Sweep and insert into bottom rail, notched end first (see figure 3d). Crimp slot when done.

STEP 4

Install Door and Panel Assemblies

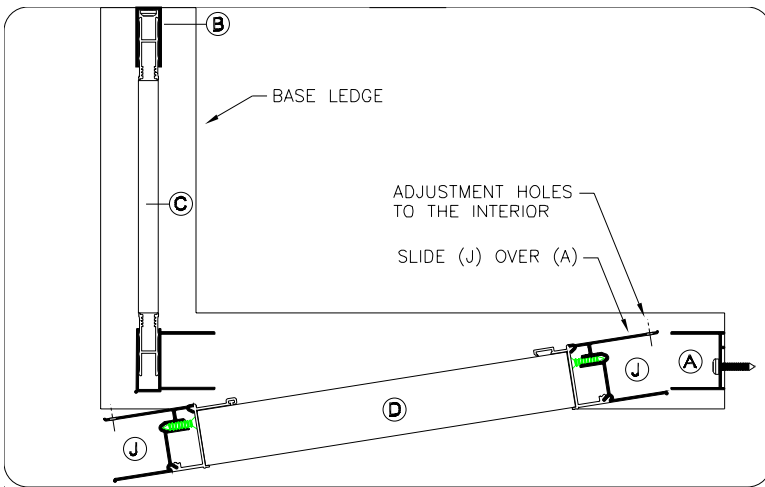

figure 4

Lift Door Assembly (D) and Panel Assembly (C) onto the base ledge and slide them onto their respective Wall Jamb (A & B) as shown above.

STEP 5

Work Corner and Secure Unit

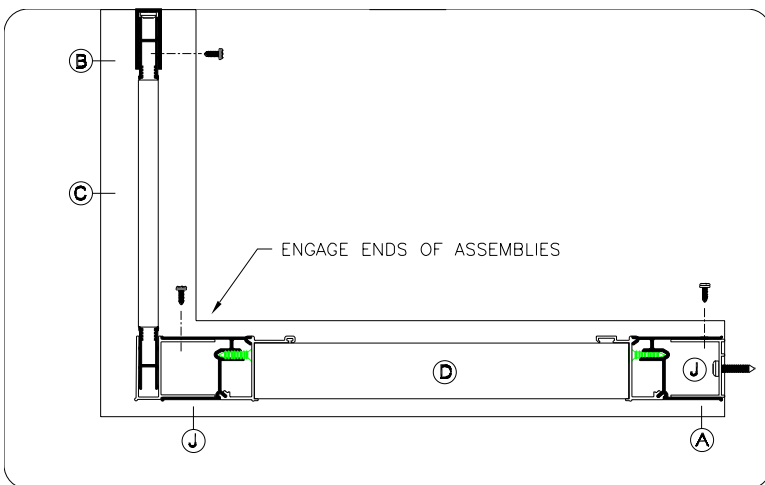

figure 5

Work the corner of the Door and Panel assemblies to engage their full length as shown in figure 5. After assemblies are engaged . . . adjust the unit along the curb as required.

When satisfied, secure the Door and Panel Assemblies to the Wall Jamb using six(6) #6 x 3/8" self drilling phillips screws (G) three(3) per side. Secure Assemblies to each other at corner using three(3) #6 x 3/8" self drilling phillips screws (G).

STEP 6

Caulk for a leak proof installation

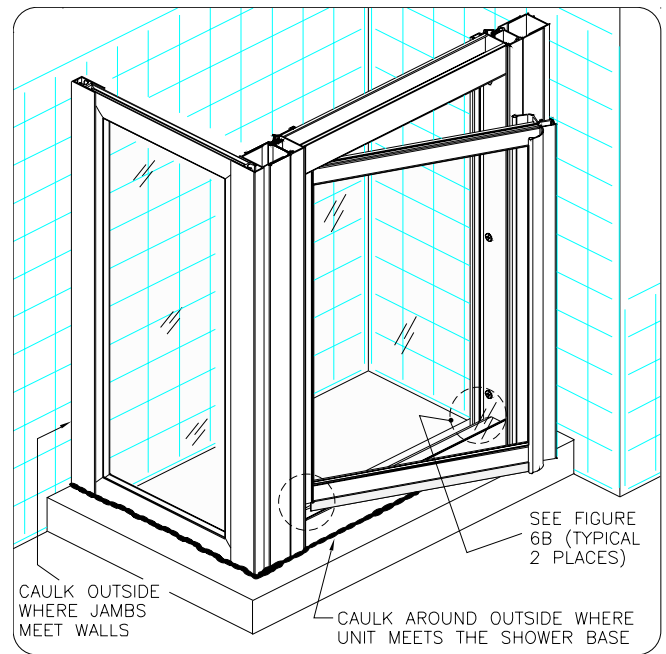

figure 6

TO INSURE A LEAK PROOF INSTALLATION:

First: Run a bead of clear mildew resistant caulking around the outside of shower enclosure where shower unit meets the shower base and where Wall Jamb meet wall (see figure 6).

Second: From inside the shower unit, caulk the two(2) circled areas indicated in figure 6 above (caulk the crevice where the horizontal member meets the vertical member as shown in figure 6b).

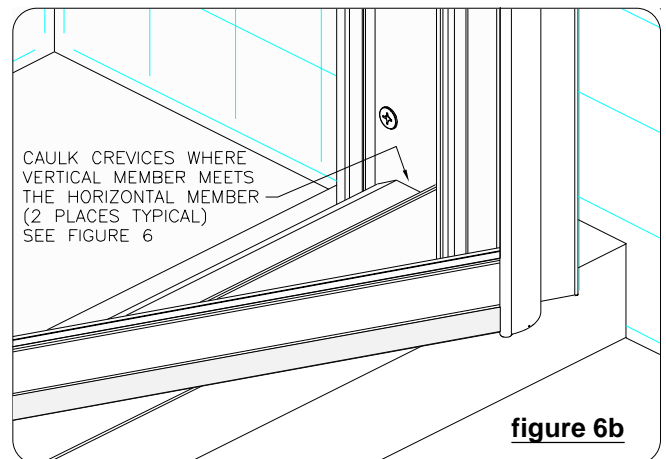
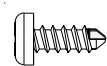

figure 6b

Carefully follow caulking manufacturer's instructions before using shower.

Unit Installation Screws (shown full size for reference)



(G)_638PHPT SELF DRILLING SCREW



(F)_834PFH FLAT HEAD SCREW

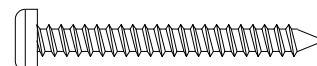

(E)_8112 PAN HEAD SCREW